

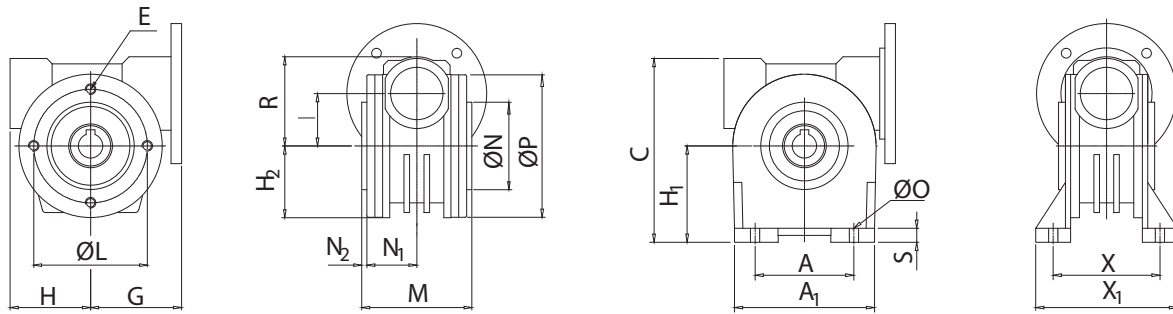

RIDUTTORI A VITE SENZA FINE ASSE 90° - SERIE "CMRBV" - "CMRBW" WORM GEAR UNITS - AXIS 90° - "CMRV" - "CMRBW"

Dimensione grandezze 030-086 | Dimension sizes 030-086



CMRBV	Ingombri/External dimension				Attacco laterale/Side fixing				Piedini/Feet mounting							kg				
Taglia Size	I	H	H2	G	R	M	N1	N2	ØP	ØL	ØN (H8)	E	C	A	A1	X	X1	S	Ø0	kg
030	30	46	41	52	48	63	30	1,5	77	65	50	M6x7 (n.4)	103	50	82	66	80	8	6,5	1,0
044	44,6	54	52	65	67,6	74	35	2	80	65	50	M6x8 (n.4)	139,6	52	99	81	101	10	8,5	2,1
049	49,5	63	56	70	77,5	82	37	2,5	108	94	68	M6x7 (n.4)	159,5	63	108	98,5	126	10	8,5	3,0

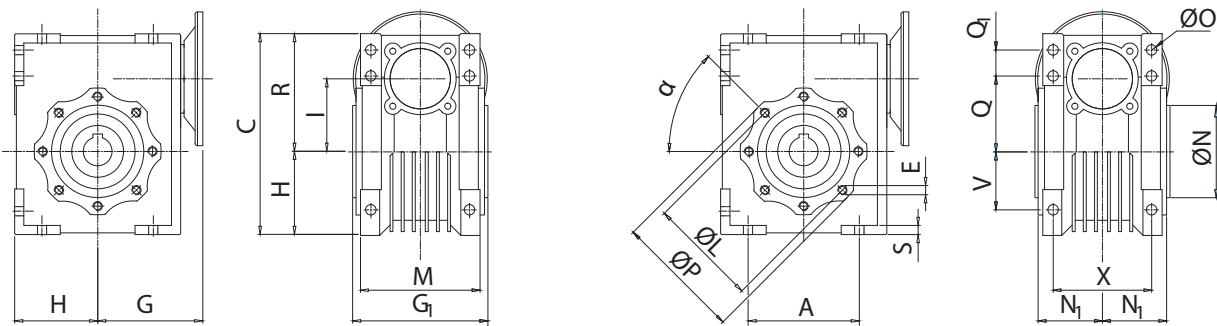

CMRBW	Ingombri/External dimension				Attacco laterale/Side fixing				Piedini/Feet mounting							kg				
Taglia Size	I	H	C	G	R	M	ØP	ØL	ØN (H8)	N1	α	E	A	X	Q	Q1	V	S	Ø0	kg
063	62,17	72,5	182,5	102	110	106	105	90	75	56	45°	M8x14 (n.8)	102	76	80	51	51	8	9	5,2
075	75	87	220,5	122,5	133,5	117	125	110	90	61,5	45°	M8x14 (n.8)	126	82	93	63	63	9	11	9,2
086	86,9	100	245,5	135	145,5	129	150	130	110	68	45°	M10x18 (n.8)	144	101	102	72	72	11	11,5	12,2



RIDUTTORI A VITE SENZA FINE ASSE 90° - SERIE "CMRBV" - "CMRBW" WORM GEAR UNITS - AXIS 90° - "CMRV" - "CMRBW"

Predisposizione attacco motore | Motor Flange Adapter

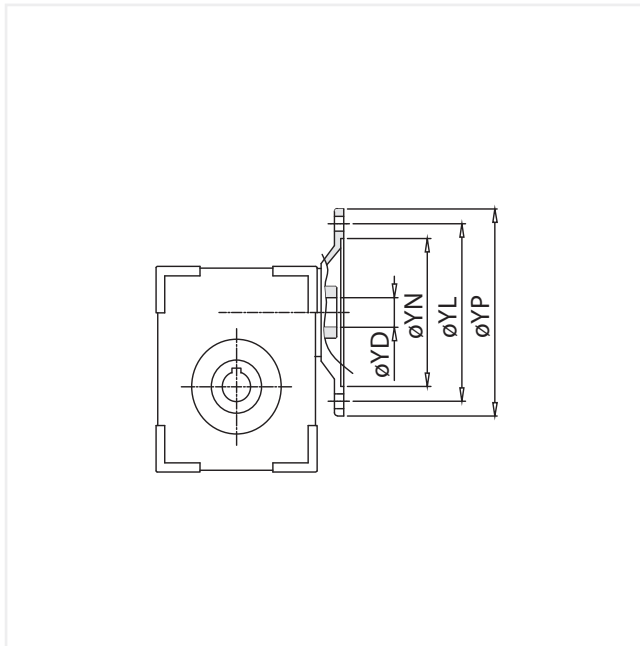

IEC

Attacco Motore/Motor Adapter

Tg Motore Motor Size	Ø YD (H7)	Flangia Flange	Ø YP	Ø YL	Ø YN (H8)
56	9	B14	80	65	50
		B5	120	100	80
63	11	B14	90	75	60
		B5	140	115	95
71	14	B14	105	85	70
		B5	160	130	110
80	19	B14	120	100	80
		B5	200	165	130
90	24	B14	140	115	95
		B5	200	165	130
100/112	28	B14	160	130	110
		B5	250	215	180

LEGENDA / LEGEND:

- Ø YD = diametro esterno / outer diameter
- Ø YP = diam. albero motore / motor shaft diam.
- Ø YL = interasse fori / bores PCD
- Ø YN = diametro di centraggio / centering diam.

CMRBV

PAM disponibili/PAM available

Taglia Size	PAM		Ø YP (H7)	Rapporti di riduzione / Ratios										
	B14	B5		7	10	15	20	30	40	60	70			
030	56B14	56B5	9	7	10	15	20	30	40	60	70			
	63B14	63B5	11	7	10	15	20	30	40	60				
044	63B14	63B5	11	7	10	14	20	28	35	46	60	70	100	
	71B14	71B5	14	7	10	14	20	28	35					
049	63B14	63B5	11								60	70	80	100
	71B14	71B5	14	7	10	14	18	24	28	36	45	60		
	80B14	80B5	19	7	10	14	18	24	28					

CMRBW

PAM disponibili/PAM available

Taglia Size	PAM		Ø YP (H7)	Rapporti di riduzione / Ratios										
	B14	B5		7	10	12	15	19	24	30	38	45	64	80
063	71B14	71B5	14								45	64	80	100
	80B14	80B5	19	7	10	12	15	19	24	30	38	45	64	
	90B14	90B5	24	7	10	12	15	19	24	30	38			
075	-	71B5	14										80	100
	80B14	80B5	19					25	30	40	50	60	80	100
	90B14	90B5	24	7	10		15	20	25	30	40	50	60	
	100B14	100B5	28	7	10		15	20						
086	80B14	80B5	19						40	46	56	64	80	100
	90B14	90B5	24	7	10	15	20	23	30	40	46	56	64	80
	100B14	100B5	28	7	10	15	20	23	30					

NOTA: l'attacco 100B14 e 100B5 sono uguali ai 112B14 e 112B5
NOTE: adapter 100B14 and 100B5 is same of 112B14 and 112B5



RIDUTTORI A VITE SENZA FINE ASSE 90° - SERIE "CMRBV" - "CMRBW" WORM GEAR UNITS - AXIS 90° - "CMRV" - "CMRBW"

CMRBV / CMRBW - Prestazioni | Performances - n1=1400rpm

CMRBV / CMRBW

Prestazioni/Performances - n1=1400rpm

Taglia Size	Rapporto Ratio	Vel.in uscita Output speed n ₂ (rpm)	Motore / Motor (4 poli/poles , 1400rpm)				P _n (Kw)	M _n (Nm)	η %
			Taglia/Size	P ₁ (kW)	M ₂ (Nm)	f.s.			
CMRBV 030	7	200,0	63C4	0,25	10	1,6	0,41	16	84
	10	140,0	63C4	0,25	14	1,2	0,30	16	81
	15	93,0	63C4	0,25	19	1,0	0,24	18	76
	20	70,0	63C4	0,25	25	0,8	0,19	18	73
	30	47,0	63B4	0,18	24	0,8	0,15	20	65
	40	35,0	63A4	0,12	20	1,0	0,12	19	60
	60	23,3	56B4	0,09	19	1,0	0,09	19	51
	40	35,0	63A4	0,12	20	1,0	0,12	19	60
CMRBV 044	7	200,0	71C4	0,55	23	1,4	0,75	29	86
	10	140,0	71C4	0,55	32	0,9	0,51	29	84
	14	100,0	71B4	0,37	29	1,0	0,37	29	81
	20	70,0	71B4	0,37	39	1,0	0,37	39	77
	28	50,0	63C4	0,25	34	1,2	0,29	39	71
	35	40,0	63C4	0,25	41	1,0	0,25	39	68
	46	30,0	63C4	0,25	50	0,8	0,19	39	63
	60	23,3	63B4	0,18	43	0,9	0,16	39	58
	70	20,0	63A4	0,12	32	0,9	0,11	29	55
	100	14,0	63A4	0,12	38	0,8	0,09	28	47
CMRBV 049	7	200,0	80C4	1,10	45	1,2	1,30	54	86
	10	140,0	80C4	1,10	63	0,9	1,00	59	84
	14	100,0	80B4	0,75	58	1,2	0,90	65	81
	18	78,0	80B4	0,75	72	0,8	0,60	59	78
	24	58,0	80A4	0,55	68	0,9	0,50	63	75
	28	50,0	80A4	0,55	75	1,0	0,55	74	71
	36	39,0	71B4	0,37	61	1,1	0,42	69	67
	45	31,0	71B4	0,37	72	0,9	0,33	65	63
	60	23,3	63C4	0,25	59	1,0	0,25	59	58
	70	20,0	63C4	0,25	64	0,8	0,21	55	54
	80	17,5	63B4	0,18	51	1,1	0,19	54	52
	100	14,0	63A4	0,12	38	1,1	0,13	49	47

"Motore / Motor"

P₁ (kW)

M₂ (Nm)

f.s.

P_n (kW)

M_n (Nm)

η %

Taglia motore max ammessa / Max motor size

Potenza motore / Motor power

Coppia in uscita / Output torque

Fattore di servizio con motore applicato / Service factor with applied motor

Potenza nominale a 1400rpm in ingresso / Nominal input power at 1400rpm

Coppia nominale in uscita con 1400rpm in ingresso / Nominal output torque with input at 1400rpm

Rendimento indicativo con 1400rpm in ingresso / Approx efficiency with input speed of 1400rpm



RIDUTTORI A VITE SENZA FINE ASSE 90° - SERIE "CMRBV" - "CMRBW" WORM GEAR UNITS - AXIS 90° - "CMRV" - "CMRBW"

CMRBV / CMRBW - Prestazioni | Performances - n1=1400rpm

CMRBV / CMRBW

Prestazioni/Performances - n1=1400rpm

Taglia Size	Rapporto Ratio	Vel.in uscita Output speed n2 (rpm)	Motore / Motor (4 poli/poles , 1400rpm)				Pn (Kw)	Mn (Nm)	η %
			Taglia/Size	P1 (kW)	M2 (Nm)	f.s.			
CMRBW 063	7	200,0	90LB4	2,20	93	1,3	2,90	120	88
	10	140,0	90LB4	2,20	129	1,1	2,40	140	86
	12	117,0	90LB4	2,20	153	0,9	2,00	140	85
	15	93,0	90L4	1,50	128	1,2	1,80	150	83
	19	74,0	90L4	1,50	157	0,9	1,40	150	81
	24	58,0	90S4	1,10	141	1,1	1,20	155	78
	30	47,0	90S4	1,10	165	1,0	1,10	160	74
	38	37,0	90S4	1,10	199	0,8	0,85	155	70
	45	31,0	80B4	0,75	155	0,9	0,71	145	67
	64	21,9	80A4	0,55	146	0,9	0,47	125	67
	80	17,5	71B4	0,37	113	1,0	0,38	115	56
	100	14,0	71B4	0,37	129	0,9	0,33	115	51
CMRBW 075	7	200,0	112M4	4,00	172	1,1	4,40	190	90
	10	140,0	112M4	4,00	240	1,0	3,80	230	88
	15	93,0	100LB4	3,00	262	1,0	2,90	250	85
	20	70,0	90LB4	2,20	249	1,0	2,20	250	83
	25	56,0	90L4	1,50	205	1,2	1,80	250	80
	30	47,0	90L4	1,50	235	1,1	1,70	270	77
	40	35,0	90S4	1,10	216	1,2	1,30	255	72
	50	28,0	90S4	1,10	255	0,9	0,95	220	68
	60	23,3	80B4	0,75	200	1,0	0,75	200	65
	80	17,5	80A4	0,55	177	1,0	0,56	180	59
	100	14,0	71B4	0,37	139	1,1	0,40	150	55
	CMRBW 086	7	200,0	112L4	5,50	234	1,1	5,90	250
10		140,0	112M4	4,00	240	1,2	4,80	290	88
15		93,0	112M4	4,00	349	1,0	3,80	330	85
20		70,0	100LB4	3,00	344	0,9	2,80	320	84
23		61,0	90LB4	2,20	283	1,1	2,50	320	82
30		47,0	90LB4	2,20	340	1,1	2,40	370	76
40		35,0	90L4	1,50	307	1,1	1,60	330	75
46		30,0	90L4	1,50	349	1,0	1,50	340	73
56		25,0	90S4	1,10	294	1,0	1,10	300	70
64		21,9	90S4	1,10	326	0,9	0,94	280	68
80		17,5	80B4	0,75	262	1,0	0,73	255	64
100		14,0	80A4	0,55	221	1,0	0,57	230	59

"Motore / Motor"

P1 (kW)

M2 (Nm)

f.s.

Pn (kW)

Mn (Nm)

η %

Taglia motore max ammessa / Max motor size

Potenza motore / Motor power

Coppia in uscita / Output torque

Fattore di servizio con motore applicato / Service factor with applied motor

Potenza nominale a 1400rpm in ingresso / Nominal input power at 1400rpm

Coppia nominale in uscita con 1400rpm in ingresso / Nominal output torque with input at 1400rpm

Rendimento indicativo con 1400rpm in ingresso / Approx efficiency with input speed of 1400rpm